

ENSEMBLE
" RAVAGEUR EXPERT "

NOTICE: 396-101-034

COMPOSITION

Deux disques pour travail bout d'arbre, diamètre de coupe 140 mm
alésage 30 mm (réf : 474.314) ou 160 mm (réf : 474.516)

Un jeu de 2 couteaux rainure de 16 mm (réf : 563.916)

Un Porte-outils "PROFIL-PLUS" , lésage 30 mm ou 50 mm (réf : 461.531 ou 461.551)

Un jeu de 2 couteaux (réf : 537.135)

Un jeu de 2 couteaux congé 1/4 rond de 12 mm (réf : 537.223)

Un jeu de 2 couteaux mouchette 8 mm (réf : 537.248)

Un jeu de bagues minces (réf : 780.531)

Une clé de serrage 6 pans (réf : 791.204)

Une clé de serrage 4 pans (réf : 791.252)

Un manchon bout d'arbre (réf : 784.617 ou 784.618)

Une cale de réglage (réf : 780.950)

Un coffret de rangement en polypropylène

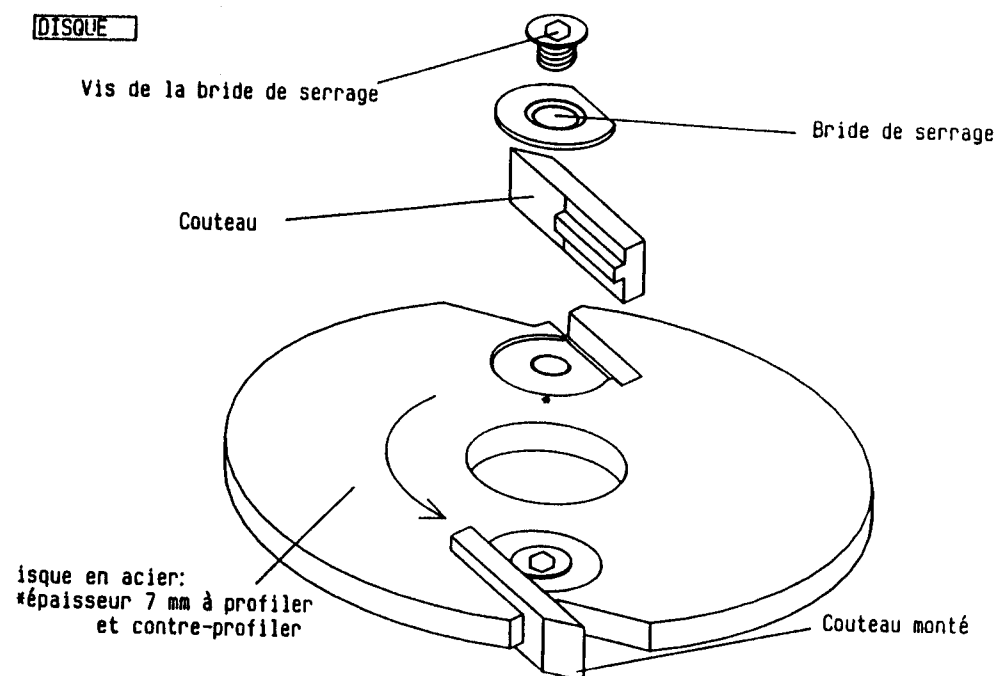

FONCTIONS DE BASES

FEUILLURE:

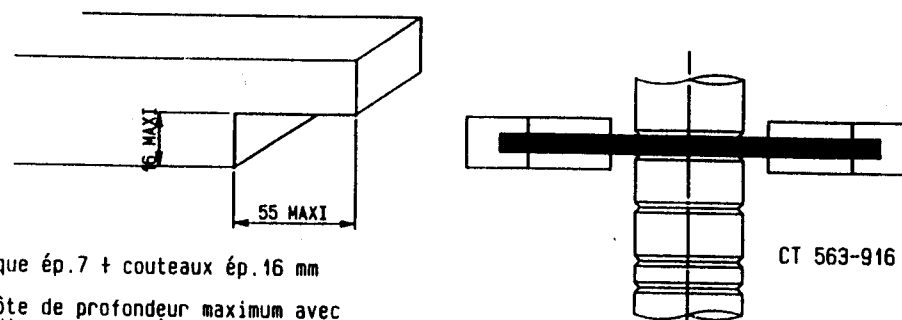

TENON LONG:

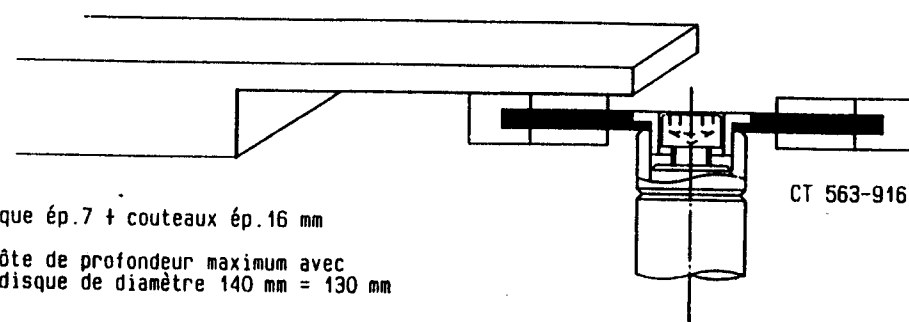

TENON SIMPLE:

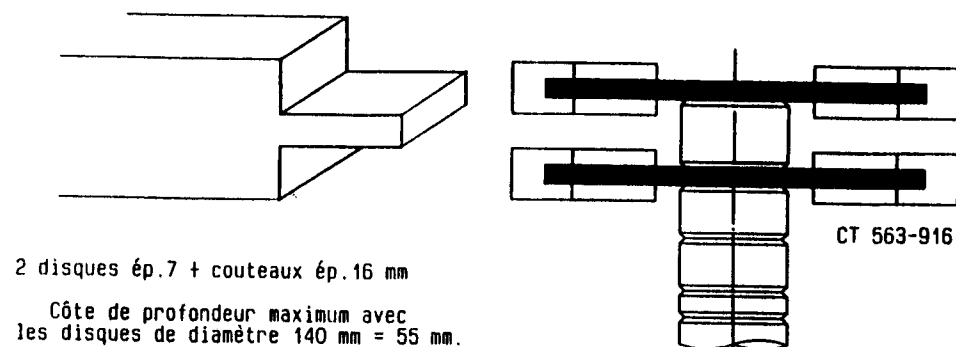

PROFIL PLUS

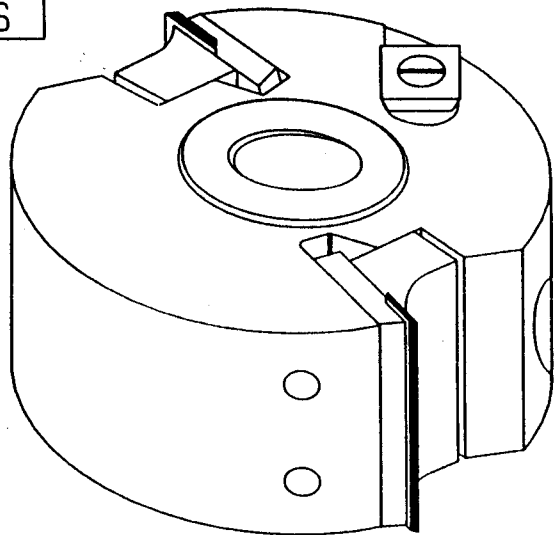

MONTAGE ET POSITIONNEMENT DE LA PLAQUETTE CARBURE (1-2-3)



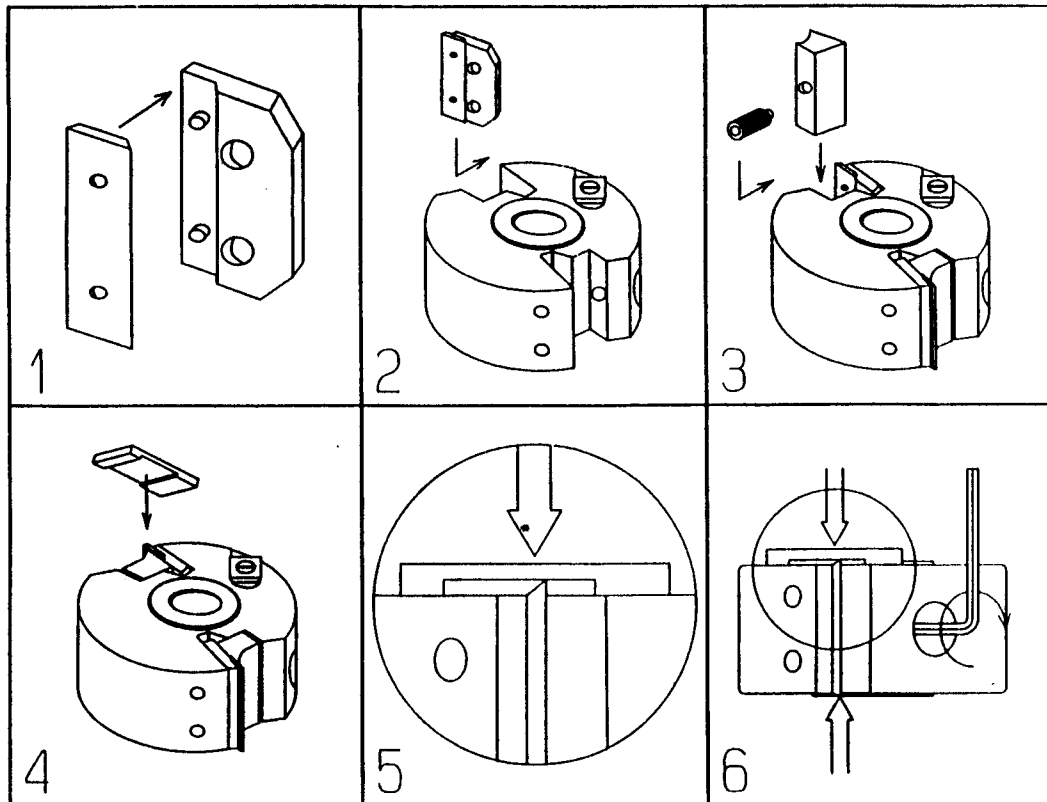



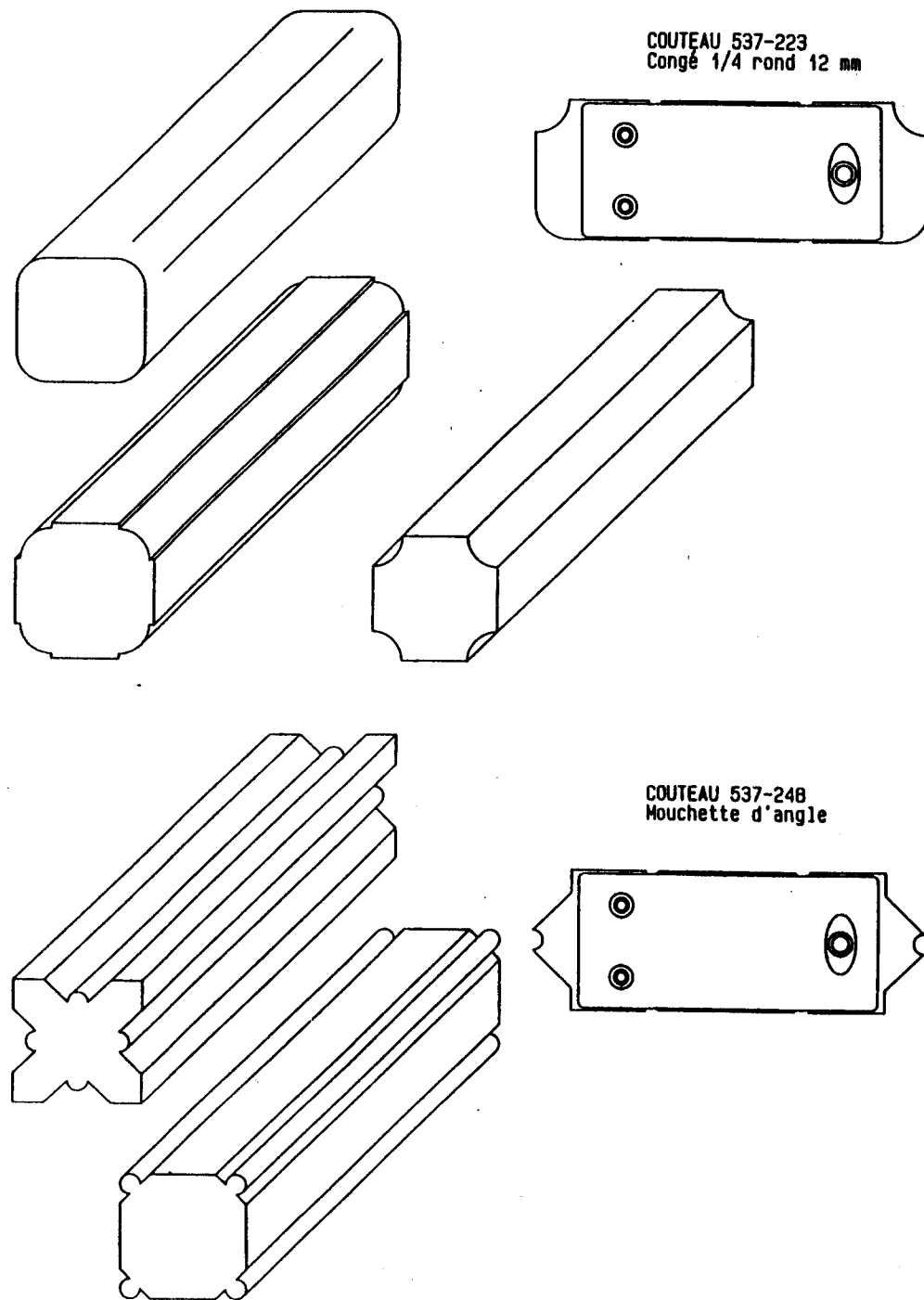

MAINTENIR LA PLAQUETTE CARBURE ET LA CALE PUIS SERRER (4-5-6)

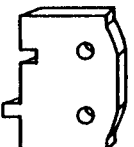
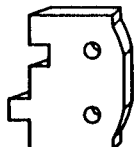
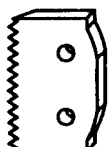

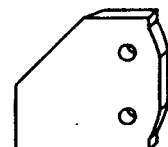
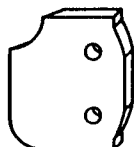
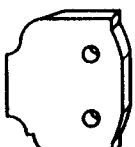
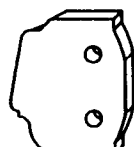
Exemples de réalisations, de pieds de table ou de pieds de chaise:

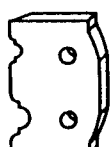

COUTEAUX SERIE 537

	 Acier 537-050/051 Carbure 537-950	 537-125 Rainure-lang 5	 537-128 Rainure-lang 8
 537-134 Enture multiple 4	 537-215 Petit bois	 537-222 Chanfrein inf 45°	 537-223 Conge-1/4 rond 12
 537-233 Multimoulture	 537-234 Multimoulture	 537-243 Jet d'eau	 537-246 Louis XV- 1/4 rond
 537-247 Double astragale	 537-248 Mouchette	 537-252 Baguette Louis XV	 537-255 Doucine - 1/4 rond

ASSEMBLAGE PAR ABOUTAGE "LE RAVAGEUR"

AVEC LE JEU DE COUTEAUX 537-135



USINAGE DE LA PREMIERE PIECE

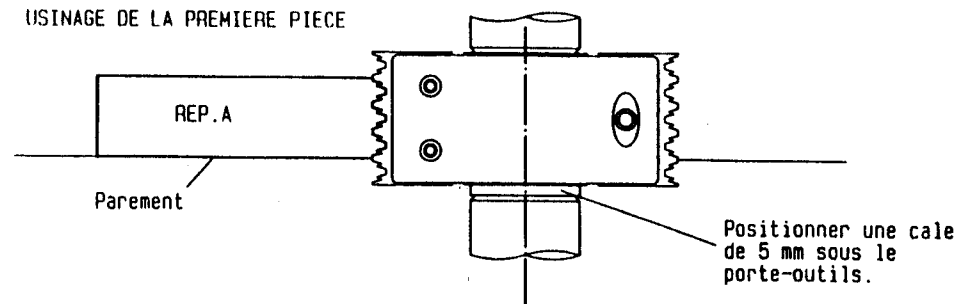

USINAGE DE LA SECONDE PIECE

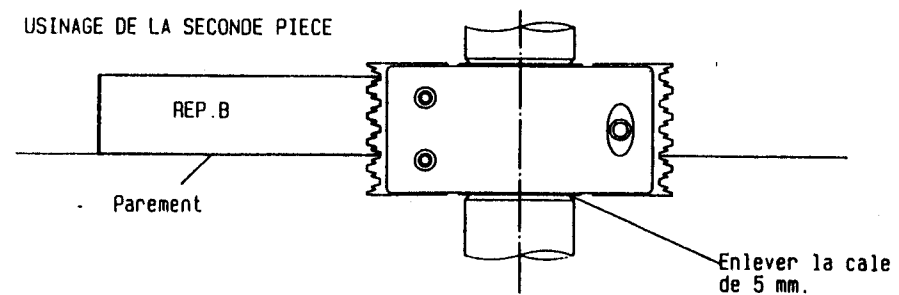

ASSEMBLAGE

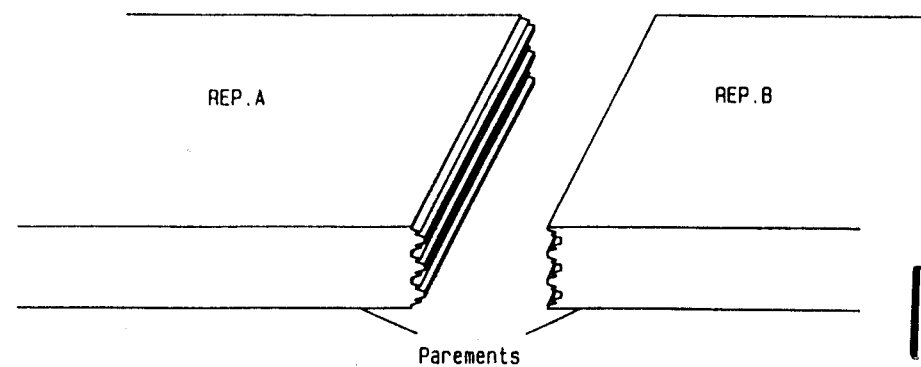

Le porte-outils "PROFIL PLUS" d'une hauteur de 50 mm permet en combinant judicieusement les couteaux disponible dans le coffret, d'obtenir une infinité de moulures.



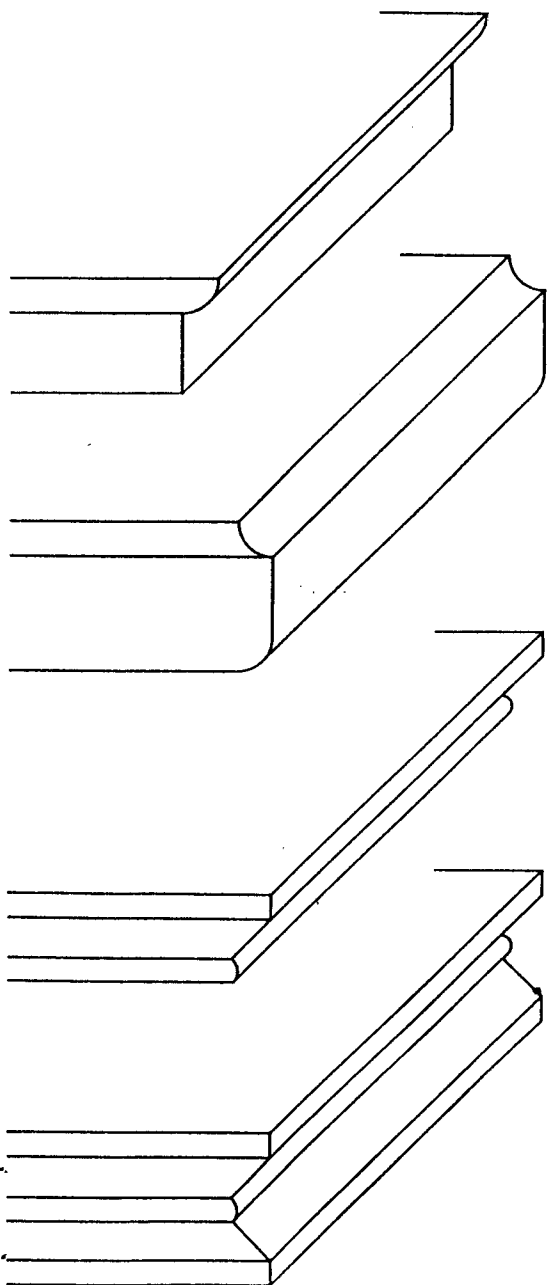

Exemples de réalisations, de bordures de tables:



COUTEAU 537-223
Congé 1/4 rond 12 mm

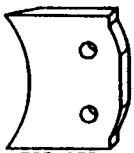
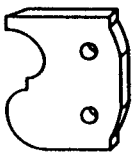
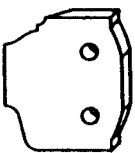

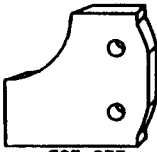
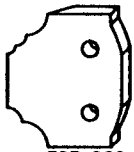
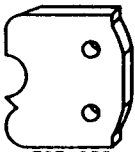
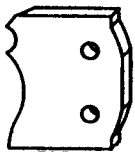
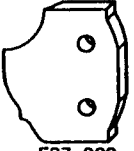
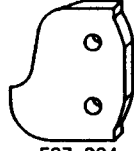
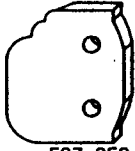
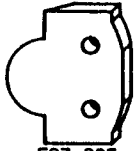
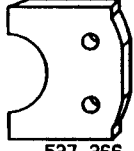
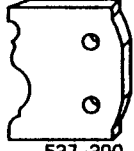
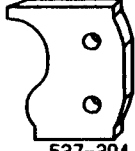
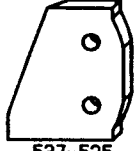
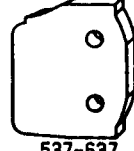
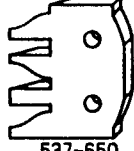
COUTEAU 537-248
Mouchette d'angle

 537-257 Main courante R40	 537-262 Bec corbin-Scotie	 537-269 Doucines	 537-276 Congé 25
 537-277 1/4 de rond 25	 537-282 1/4rond 3/4/6/8/10	 537-283 Tore a gorge-Congé	 537-291 Grain d'orge
 537-302 Doucine-Congé 12	 537-304 Doucine 1/4rond 12	 537-350 Congés 3/5/9/14	 537-365 Gueule de loup 29
 537-366 Mouton 30	 537-390 Renaissance	 537-391 Main courante	 537-525 Chanfrein inf 20°
 537-637 Plate-bande	 537-650 Profil-C/Profil	 537-701 Multiprofil	

Remarque: Outre ces couteaux H50x5,5mm le "PROFIL PLUS" est compatible avec tous les couteaux universels H40x4mm (serie 533).

OPTIONS: CES COUTEAUX PROFILS ET CONTRE-PROFILS PEUVENT SE MONTER SUR LE DISQUE PRESENT DANS CE COFFRET.

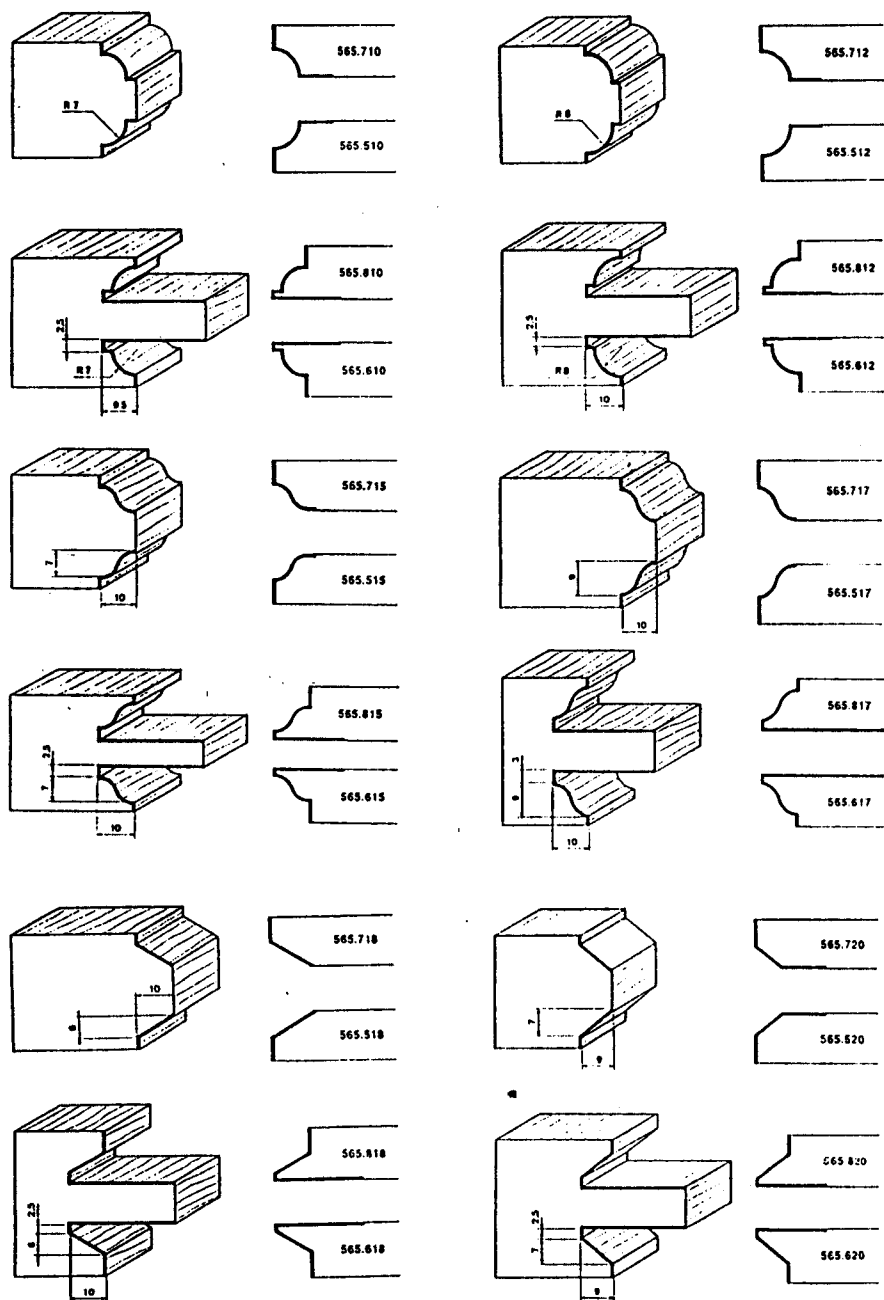

OPTIONS: CES COUTEAUX PLATE-BANDE PEUVENT SE MONTER SUR LE DISQUE PRESENT DANS CE COFFRET.

